



**USERS MANUAL FOR
DRUM STYLE SEPARATORS
SERIES ATS**

CUSTOMER: _____
SERIAL #: _____
DATE OF MFG.: _____
MODEL: _____





TABLE OF CONTENTS

- O. INTRODUCTION
- A. DIMENSIONS
- B. SPECIFICATIONS
- C. DRIVE
- D. INSTALLATION
- E. OPERATION
- F. MAINTENANCE
- G. ACCESSORIES
- H. SPARE PARTS LIST
- I. QC - SHEET
- J. HOW TO ORDER SPARE PARTS



O. INTRODUCTION

This user manual will explain the specifications concerning the Crizaf drum style separator model ATS. The user manual covers explanations from installation to operation of the drum style separator.

A. DIMENSIONS

The Crizaf drum style separators come in standard dimensions as described in the brochure. Special lengths are available based on the separation requirements and upon request or recommendation.

B. SPECIFICATIONS

1. Frame

The separator frame consists of anodized aluminum extruded profile 35mm (1.3 inches) in height by 35mm in width (1.3 inches). The part funnels and infeed/outfeed tubes are made from stainless steel sheet metal 16 gauge. Furthermore steel and aluminum die cast parts are used in areas which require high strength. All sheet metals used are 16 gauge stainless steel (1.5 mm thick). High quality ball bearings guarantee a long lasting maintenance free operation.

2. Drum

The ATS drum consists of (20) PVC rollers, which are mounted together as pairs of (2). The unique single point roller adjustment allows an easy and quick adjustment of the separation gaps for different part/runner sizes. The infeed tube is equipped with a Polyurethane spiral to slow parts down as they enter the drum. The drum rests on three nylon wheels, that run on lubricated ball bearings, and a drive pulley, which is directly driven by the variable speed motor.

Angle adjustment

A) Model ATS

The drum Separator model ATS is equipped with a swiveling telescope, lockable with a handle, located at the side of the leg assembly. To adjust the height, loosen the handles and adjust the desired angle of the separator. Then lock the separator with the handles in the desired position.



B) Model ATS - 1000 (extended drum length)

The drum separator with extended drum length is equipped with (4) independent legs. The legs are made from zinc plated perforated steel tubing to guarantee optimum resistance to corrosion and an easy height adjustment.

To adjust the angle/height on this model, follow the procedure listed below:

WARNING

Any height adjustment of the of the Separator should be made carefully.

Avoid injuries by choosing a proper lifting device.

- a. Separator height adjustment/down
 1. Secure the screw knobs that tighten the telescope to the leg tubing.
 2. Remove the height adjusting pins.
 3. Insert the pins in the proper hole setting and insert the safety pin.
 4. Release the set knob in order to slide the telescopes down to the desired position.
 5. Tighten the screw knob.

- b. Separator height adjustment/up
 1. Remove the height adjusting pins.
 2. Release the set knob in order to slide the telescopes up to the desired position.
 3. Insert the pins in the proper hole setting and insert the safety pin.
 4. Tighten the screw knob.

Note

The screw knob is not supposed to fit into the holes of the tubing.

- c. To adjust the angle of the ATS – 1000 drum Separator use a lower hole in the perforated tubing at the front than at the rear.



C. DRIVE

1. Motor

The standard gearmotor is a Dayton 1/8 HP, 90VDC gear motor with 109RPM

2. Control

The standard control is a DC variable speed control. This standard unit is overload protected and mounted inside a NEMA 1 enclosure.

3. Power transmission

A directly driven rubber pulley transmits the power to the drum. The speed can be adjusted by turning the potentiometer of the DC speed control. This will increase or decrease the speed of the drum rotation.

D. INSTALLATION

Every ATS Separator is shipped pre-tested at the factory. All Separators are shipped with a 15 feet cord terminating with a standard 3-prong plug ready to be plugged in any 110 VAC receptacle with ground. The direction of rotation is factory preset.

The Separator is shipped broken down into the following components:

1. the base frame assembly
2. the separation drum
3. the leg base assembly

To assemble the Separator perform as follows: (the numbers refer to the attached spare parts design).

1. Uncrate the unit.
2. Screw the (4) casters (#61) into the threaded plates on the bottom of the leg base (#2).
3. Attach the perforated leg (#3) to the mounting plate (# 67) by utilizing the bolt (#57), the washer (#55/53) and the nuts (#51/52) as shown in the drawing. Then attach the handle (#56) to the leg by sliding it through the half moon slot in the mounting plate and tighten it in the leg.



4. Now slide the perforated leg into the base leg assembly. Use the pin (#59) and the safety pin (#58) to set the height of the Separator.
5. Ensure that the base sits in a horizontal position on the leg assembly. Now lift up the drum of the separator and rest it on the three nylon pulleys (#23) and the drive pulley (#37). Ensure that the drum sits in front of the collar on the nylon pulleys.
6. At last install the Lexan safety shielding (#17) by sliding it into the slots of the stainless steel enclosure (# 34/35)
7. The separator can now be plugged into any 110VAC 60Hz grounded power outlet and operate.

E. OPERATION

To operate the ATS drum Separator, perform the following:

1. Plug the power cord into a 110VAC 60Hz power source.
2. Adjust the Separator to the desired angle by utilizing the handle (#56).
3. Adjust the desired separation gap, by following the procedure described below.
4. The Potentiometer adjusts the speed of the unit and works as the on / off switch at the same time. To turn the unit on, turn the potentiometer to the desired percentage. To turn off the unit, turn the potentiometer all the way back to 0%, until you feel a resistance and hear a click noise.

Procedure to adjust the separation gap:

The ATS drum Separator is equipped with a unique single point roller adjustment. To adjust the gaps between the PVC roller pairs loosen the screw (#7) at the front of the separation drum cover (#5) with a 5mm metric "Alan Wrench". Now rotate one of the roller sets clock- or counter-clockwise to adjust the desired separation gap. The remaining sets of rollers will follow simultaneously, as you adjust one set.

When the separation gaps are as desired, tighten the screw (#7) and the Separator is ready to be used.

WARNING!
ALWAYS KEEP THE SAFETY ENCLOSURE
IN PLACE. KEEP HANDS AWAY FROM MOVING/
ROTATING COMPONENTS!

WARNING



THIS SEPARATOR IS DESIGNED TO OPERATE IN A REASONABLY CLEAN, DUST-FREE AND MOISTURE-FREE INDUSTRIAL ENVIRONMENT! OPERATING THE SEPARATOR IN A WET ENVIRONMENT OR IN THE PRESENCE OF OIL, METAL SHAVINGS, ETC., IS DANGEROUS FOR THE OPERATOR! THIS MAY CAUSE DAMAGE TO THE SEPARATOR AND VOID THE WARRANTY!

F. PREVENTIVE MAINTENANCE

The ATS Separator is essentially maintenance free. However, a few easy preventive maintenance steps will increase the lifetime of the Separator.

1. Keep the Separator clean! Especially moving parts, like drum, and motor pulley can create an additional load on the motor if they are not clean. Make sure that no plastic parts are caught between the drum and the outer sheet metal protection. To clean the Separator do not use sharp cleaners or alcohol. Use a common household cleaner with warm water to clean the components of the Separator.
2. Attached with the Separator spare parts list is a list of wear items. To keep these items in stock will reduce the down time of your Separator, if it needs to be repaired.

G. ACCESSORIES

1. **Discharge chute for 90° setup with feeding conveyor.** 16 gauge stainless steel chute, with standard hardware for mounting on the discharge end of the Separator.

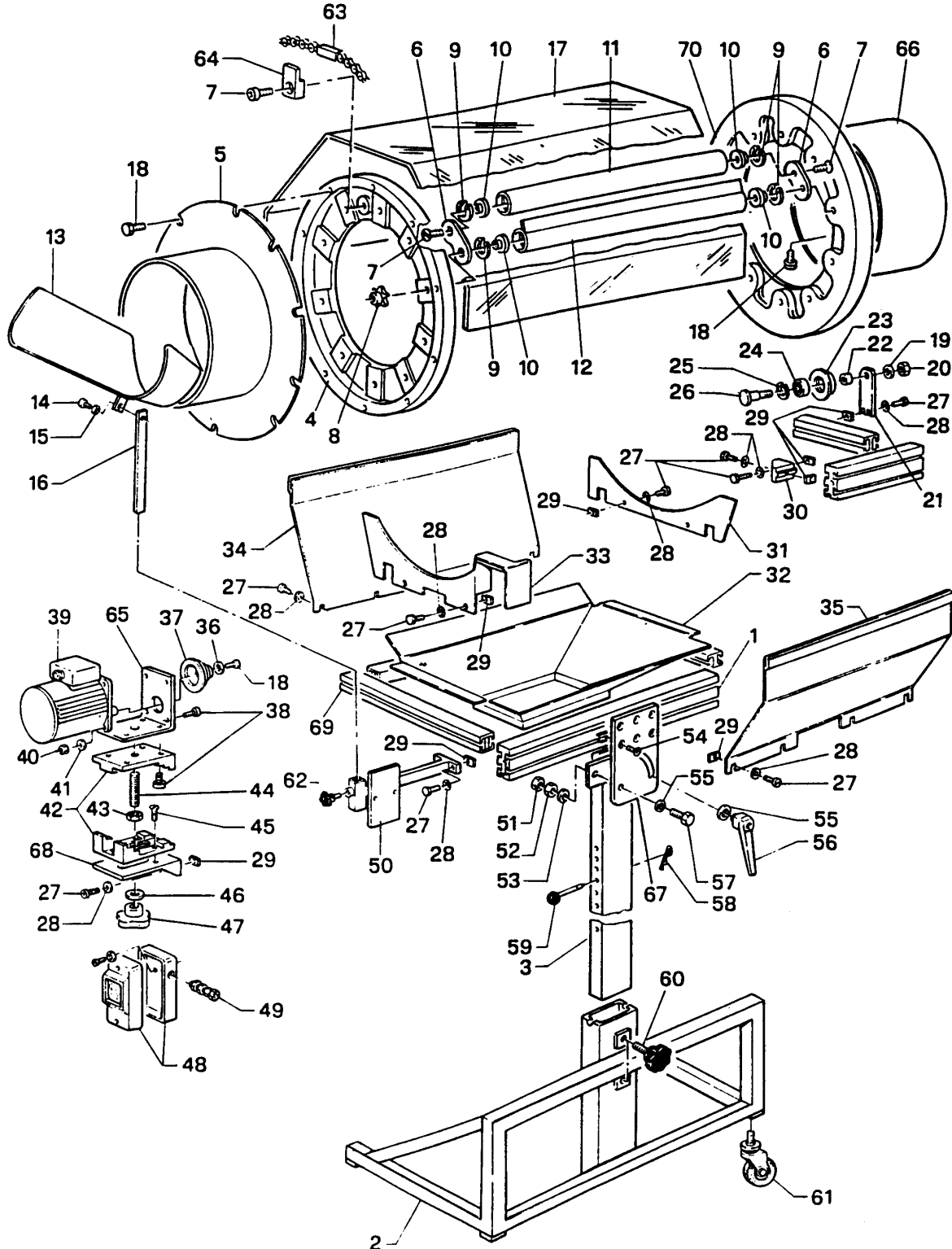



Pos.	Description	Order #	Recommended Spare Parts
01	Extruded aluminum profile type L	ATS 01	
02	STD base for ATS	ATS 02	
03	Perforated leg 70 x 30mm	ATS 03	
04	Aluminum collar - infeed end – ATS	ATS 04	
05	Infeed tubing with cover- stainless	ATS 05	
06	Connection plate for roller	ATS 06	
07	Screw, TCE M6 x 25	ATS 07	
08	Sprocket for ATS	ATS 08	
09	Seeger, Ø 44 mm ID	ATS 09	
10	Roller head piece PVC	ATS 10	
11	PVC roller, Ø 50 mm	ATS 11	
12	PVC roller Ø 50 mm with PVC flap,	ATS 12	
13	Infeed chute	ATS 13	
14	Hex head screw TE M10 x 25	ATS 14	
15	Lock washer, Ø 10 mm	ATS 15	
16	Support rod for infeed chute	ATS 16	
17	LEXAN enclosure	ATS 17	
18	Screw, TC M4 x 16	ATS 18	
19	Washer, Ø 8-24 mm	ATS 19	
20	Nut, M8	ATS 20	
21	Idle wheel support	ATS 21	
22	Spacer, Ø 9 mm	ATS 22	
23	Nylon idle wheel, Ø 58 mm	ATS 23	3
24	Bearing 6202 ZZ	ATS 24	3
25	Seeger, Ø 35 mm ID	ATS 25	
26	Shaft for nylon wheel	ATS 26	
27	Hex head screw, TE M8 x 20	ATS 27	
28	Washer, Ø 8 mm	ATS 28	
29	Square nut, M8	ATS 29	
30	Angle bracket	ATS 30	
31	Rear protection – stainless	ATS 31	
32	(4) sided bottom tray for ATS	ATS 32	
33	Front protection – stainless	ATS 33	
34	Protection LH – stainless	ATS 34	
35	Protection RH – stainless	ATS 35	
36	Washer, Ø 4-16 mm	ATS 36	
37	Step drive pulley (AC MOTOR)	ATS 37	1
37 A	Straight drive pulley (90VDC VERSION)	ATS 37 A	1
38	Screw, TCE M5 x 15	ATS 38	
39	90 VDC variable speed motor 1/20 HP	ATS 39	
40	Nut, M6	ATS 40	
41	Washer, Ø 6mm	ATS 41	
42	Adjustable motor plate (AC MOTOR ONLY)	ATS 42	
43	Nut, M10	ATS 43	



Pos.	Description	Order #	Recommended Spare Parts
44	Screw, STP M10x80	ATS 44	
45	Screw, TPCSE M5 x 20	ATS 45	
46	Washer, Ø 10-30 mm	ATS 46	
47	Hand Wheel, Ø 50 mm M10	ATS 47	
48	DC speed control (90 VDC MOTOR)	ATS 48	
49	Cable protection	ATS 49	
50	Mounting bracket DC control / Motor starter	ATS 50	
51	Nut, M12	ATS 51	
52	Nut, M12 - flat	ATS 52	
53	Washer, Ø 12-24 mm	ATS 53	
54	Screw, TPSCE M8 x 18	ATS 54	
55	Washer, Ø 12-36 mm	ATS 55	
56	Handle, M12 x 30	ATS 56	
57	Hex head screw, TE M12 x 40	ATS 57	
58	Safety pin	ATS 58	
59	Pin with plastic ball	ATS 59	
60	Screw knob, Ø 40 M10 x 15	ATS 60	
61	Pivoting caster, Ø 50 mm	ATS 61	4
62	Screw knob, Ø30 M6 x 20	ATS 62	
63	Chain	ATS 63	
64	Chain locking bracket	ATS 64	
65	Motor mounting plate (AC VERSION)	ATS 65	
66	Discharge tubing - stainless	ATS 66	
67	Mounting plate - angle adjustment	ATS 67	
68	Support for motor plate	ATS 68	
69	Transverse support - aluminum	ATS 69	
70	Aluminum collar - drum discharge end -	ATS 70	

J. HOW TO ORDER SPARE PARTS:

1. Determine the part number by utilizing the above spare part drawing and spare parts list.
2. To this number add the 6-digit serial number of the Separator.
3. Example: You want to order a Safety pin for your Separator with the serial # CE 000.

The Part number for a replacement part is: **ATS 58**

The Serial number of the Separator is: **CE 000**

THE ORDER NUMBER IS: ATS 58 CE 000

